



# END AND SILO RECEIVERS

*Nol-Tec's receivers provide long-lasting performance for termination of pneumatic conveying systems.*

## STANDARD FEATURES:

- Heavy-duty plate design
- Continuous welded construction
- Promotes separation of material and conveying air
- Long-lasting
- Field weld styles pictured below

## OPTIONAL FEATURES:

- Stainless steel construction
- Grooved or flanged pipe ends
- Rubber coated contact surface
- Mounting flange
- Replaceable internal baffle
- Abrasion resistant plate design
- Extended Body (Model 228)

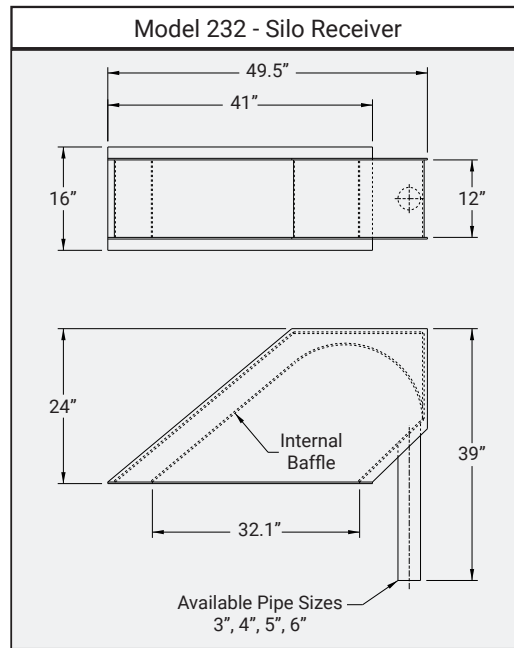
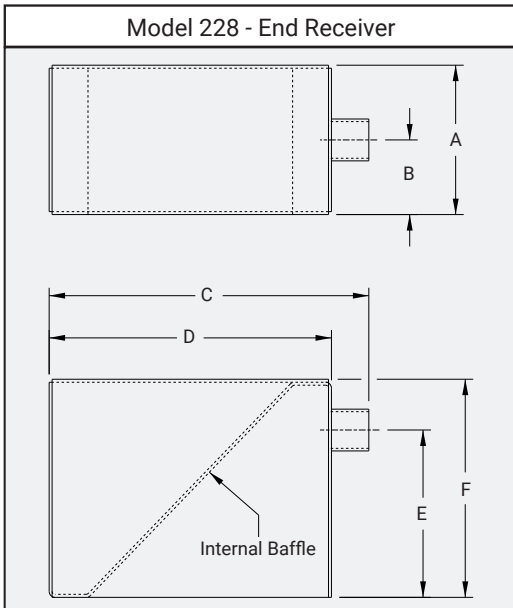

END RECEIVER						
PIPE SIZE	A	B	C	D	E	F
2"	6.38	3.19	26.50	23.38	14.00	18.25
3"	12.50	6.25	26.75	23.63	14.00	18.25
4"	12.50	6.25	26.75	23.63	14.00	18.25
5"	12.50	6.25	26.75	23.63	14.00	18.25
6"	12.50	6.25	29.50	26.38	12.25	18.25
8"	18.75	9.38	42.75	36.75	15.00	22.50
10"	18.75	9.38	42.75	36.75	15.00	22.50

Specifications subject to change without notice.

## TRUSTED TO DELIVER®

Nol-Tec Systems, Inc | 425 Apollo Drive | Lino Lakes, MN 55014  
651.780.8600 | sales@nol-tec.com | www.nol-tec.com

5.013.SALE.11.05.24.04

