



SINGLE BAG/CARTRIDGE BIN VENTS

Nol-Tec single bag/cartridge bin vents effectively filter dust laden air created by hopper filling applications.

STANDARD FEATURES:

- Reverse pulse jet cleaning
- Top filter element removal (Model 279)
- Bottom filter element removal (Model 317)
- 100% material recovery
- **Compressed air:** Clean and dry at 80 PSIG minimum
- **Electrical:** Designed to meet customer's specifications
- **Temperature range:** Polyester bags 270° F; Polyester cartridge & urethane ends 225° F

OPTIONAL FEATURES:

- Stainless steel construction
- Variety of filter media materials available
- Variety of mounting arrangements

SINGLE BAG/CARTRIDGE DUST FILTERS

MODEL	TYPE	FILTER AREA	A	B	C
279-1000	Bag	1.7 ft ²	26"	10"	5.75"
279-3000	Bag	4.6 ft ²	44"	10"	5.75"
279-250	Cartridge	2.5 ft ²	15"	6"	6.06"
279-1000	Cartridge	10 ft ²	26"	10"	6.06"
279-3000	Cartridge	30 ft ²	44"	10"	6.06"
317-6000	Cartridge	60 ft ²	33"	24"	12.75"

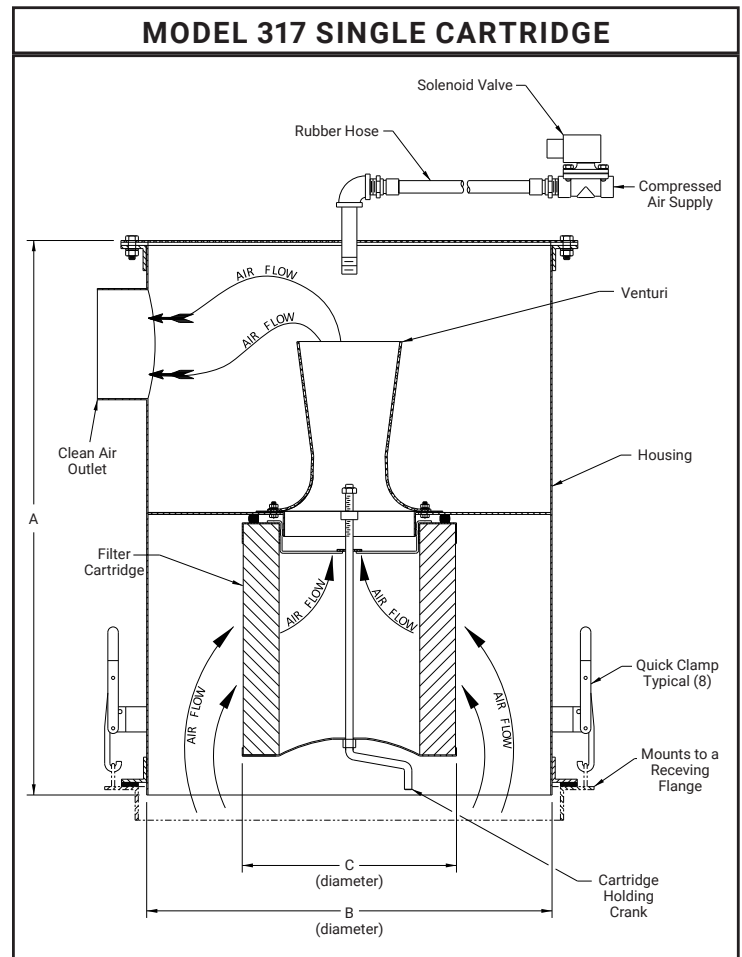
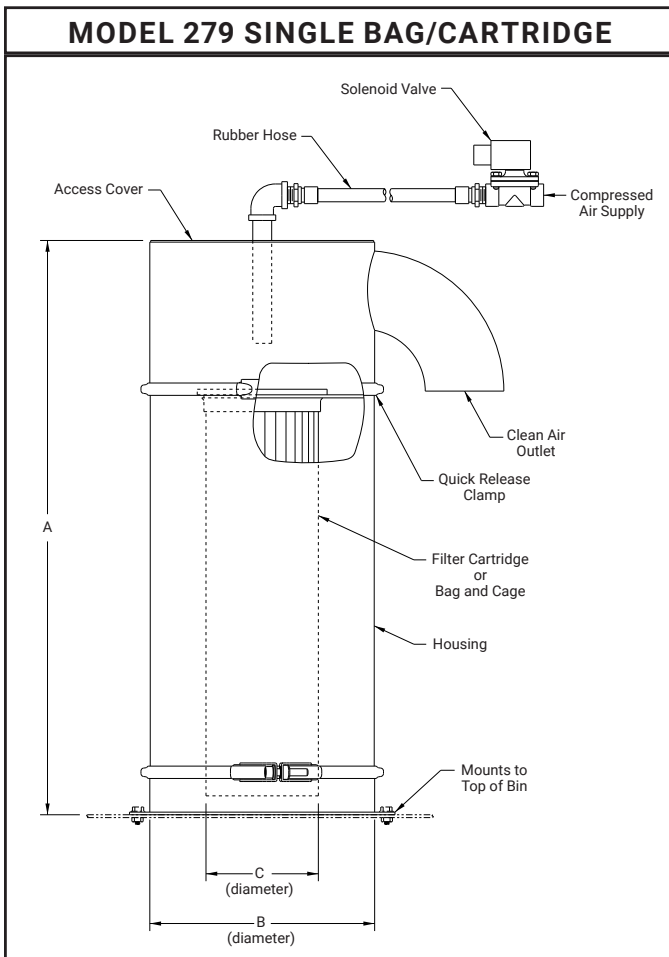

Specifications subject to change without notice.

TRUSTED TO DELIVER®

Nol-Tec Systems, Inc | 425 Apollo Drive | Lino Lakes, MN 55014
651.780.8600 | sales@nol-tec.com | www.nol-tec.com

5.025.SALE.01.02.25.06

